

QX 3440-D HIGH DENSITY MULTIPLEXER/CROSS-CONNECT

QX3440-D

- DACS (Digital Access Cross-connect System) with full DSO non blocking cross-connect with up to 72Mbps capacity
- Up to 36E1/T1 WAN
- Full modular system:
 - 2 slots controller CPU,
 - 2 slots power supplies ,
 - 9 mini slots
- Redundant CPU
- Redundant Power
- Hot swappable cards.

E1 Protection:

- 1 for 1 protection (E1, FOM)
- Circuit protection with external Y-Box
- ULSR PDH Ring protection, FOM, miniQE1

Mini-slot plug-in card types:

- ◇ E1/4E1: G703,G704, E1-CAS
- ◇ T1/4T1: G703 or CAS
- ◇ 4 E1/T1 Fiber optic
- ◇ E1 ATM/Frame Relay
- ◇ Dual 10/100baseT Router Bridge
- ◇ Terminal server 3 RS232
- ◇ V35
- ◇ EIA530
- ◇ RS232
- ◇ X21/V11
- ◇ Quad FXS
- ◇ Quad FXO
- ◇ Quad E&M 2w
- ◇ Quad E&M 4W

Power:

- ◇ Single 110-240 VAC
- ◇ Dual 48VDC
- ◇ Dual 24VDC



ACCESS MUX CROSS CONNECT



QX3440-D
2U size

The 2U chassis **QX3440-D** is a 36 E1 or T1 Multiplexer that can combine various digital access interfaces into multiples E1 or T1 lines for convenient transport and switching.

9 half slots provide access for a variety of interfaces, including RS232, V.35, V36, RS422, RS485, E&M, FXS, and FXO.

Up to 72Mbps or 36 x 31 TS could be cross-connected in this devices.

The 2U **QX3440-D** chassis is able to reuse interface card from IX4200-9.

This unit is a full cross connect or DACS for Telco or large infrastructure in utilities, transport and defense.

The **QX3440-D** support for all of this E1 or T1 WAN the non blocking features of Multiplexing, Drop & Insert, cross-connect, Broadcasting and Multicasting, at E1 or TS level.

The **QX3440-D** support the protections: (1+1) in Bus card, the PDH ULSR Ring up to 16E1 and 16 different rings and the PDH SNCP protection at the TS level over large networks.

Redundancy is available in dual CPU controller and power supply options, making it an excellent fit for critical applications. And, though the chassis does not contain and has no need for fan cooling

The router/bridge and router/bridge with switch support VLAN, VLAN tagging, and level 3 static/RIP1/RP2/OSPF routing protocol.

The **QX3440-D** supports local control and diagnostics by using an external 2-lines by 40-character LCD display and keypads, or by using a VT-100 terminal connected to the console port.. The QX 3440-D also supports Ethernet, SLIP, Telnet, and SNMPV1 2 3, so that it can be controlled and diagnosed from remote locations as well. An in-band management channel and CXRView with GUI are available. There is one status LED for each BdB, G.SHDSL, V.xx, RS422/RS485 or RS232 interface and 4 LEDs for each of the E1 or T1 lines.

The **QX3440-D** consists of a rugged chassis made from reinforced aluminum, giving this equipment a more durable structure and a longer physical life.

The **QX3440-D** in compatible with IX4200-9 application. All interfaces cards from IX4200-9 are compatible with QX3440-D

Item	QX3440-D
Multiplexer Cross-Connect	72 Mbps
Size	2U
Nb mini slots	9
Max E1/T1 ports	36

ORDERING INFORMATION

Chassis and cards	Description	Notes	
QX3440-D	2U 19" Main unit chassis without CPU, power, E1/T1 card	Deliver with rack mount 19" and 23"	
QX3440-CPU	CPU card with cross-connect with E1 clock	2 for redundancy	
QX3440-CPU-4E1-RING	CPU card with cross-connect & E1 ring software 4E1 or 4FOM	2 for redundancy	
QX3440-CPU-T1	CPU card with cross-connect with T1 clock	2 for redundancy	
QX34DD-E1	1 channel E1 interface, G703/G704/CAS		1/2 slot 4 slots available
QX34DD-T1	1 channel T1 interface, G703/G704/CAS		
QX34DD-MQE1	4 channel E1 interface, G703/G704/CAS connector DB25, support ULSR-RING	DB25 to cable 120 RJ45M	
QX34DD-MQE1-BNC	4 channel E1 interface, G703/G704/CAS connector DB25, support ULSR-RING	DB25 to cable BNC 75 ohms	
QX34DD-4E1FO-MM	4E1 Optical fiber interface, G703/G704/CAS/NonCAS, support ULSR-RING	Multi-Mode 2 km, SC interface	
QX34DD-4E1FO-SM30-SC	4E1 Optical fiber interface, G703/G704/CAS/NonCAS, support ULSR-RING	Single Mode 30 km, SC interface	
QX34DD-4E1FO-SM50-SC	4E1 Optical fiber interface, G703/G704/CAS/NonCAS, support ULSR-RING	Single Mode 50 km, SC interface	
QX34DD-4E1FO-SM30-FC	4E1 Optical fiber interface, G703/G704/CAS/NonCAS, support ULSR-RING	Single Mode 30 km, FC interface	
QX34DD-4E1FO-SM20/15-SC	4E1 Optical fiber interface, G703/G704/CAS/NonCAS, support ULSR-RING	Single Mode 20 km, SC , 1550 nm	
QX34DD-4E1FO-SM30-W13-SC	4E1 Optical fiber interface, G703/G704/CAS/NonCAS, support ULSR-RING	Single Mode 30 km, SC, WDM 1310	
QX34DD-4E1FO-SM30-W15-SC	4E1 Optical fiber interface, G703/G704/CAS/NonCAS, support ULSR-RING	Single Mode 30 km, SC, WDM 1550	
QX34DD-RTA	Bridge/Router interface: 2 Ethernet ,64 WAN, maxi throughput 4Mbps	2 x 10/100BaseT	
QX34DD-TS3-RS232	3 RS232 Async (2 possible in Sync) Terminal server mode	SW V2.02.02 and up	
QX34DD-V35	V35 interface card	SW V3.06 and up	
QX34DD-EIA530	EIA530 interface card	SW V3.06 and up	
QX34DD-X21	X21/V11 interface card	SW V3.06 and up	
QX34DD-V24	V24 interface card	SW V3.06 and up	
QX34DD-QFXO	4-channel FXO plug in module, w/600/900 impedance, Battery Reverse	Without Ground start and metering pulse.	
QX34DD-QFXS	4-channel FXS plug in module, w/600/900 impedance, Battery Reverse	Without Ground start and metering pulse.	
QX34DD-2QEM	4 channel 2W E&M plug in module, Type 1 2 3 4 or 5, Side A / B to be choose	DB44 to 4 RJ45	
QX34DD-2QEM	4 channel 4W E&M plug in module, Type 1 2 3 4 or 5, Side A / B to be choose	DB44 to 4 RJ45	
QX3440-S-PW48	Power supply module -36 to -72V 100 Watt for QX3440-S or D only	Order 2 single DC for Dual DC application	
QX3440-S-PWAC	Power supply module AC 110/230V 150 Watt for QX3440-S only	Only ONE AC power supply	
QX3440-LCD	LCD screen	Optional	
QX3440-SW-4E1-RING	E1 ring software 4E1 or 4FOM (integrated in QX3440-CPU-4E1-RING)	Software Option	
999-355-031	V.35 DB25 to M34F DTE Cable		
999-355-030	V.35 DB25 to M34M DCE Cable		
PW-230AC-48-150-xx	Power supply 230Vca to -48Vcc 150W	Xx= Eur/UK/USA	
PROTEC-4E1	1 for 1 protection Y-Box with RJ48C connectors (4E1)		
PROTEC-16E1	1 for 1 protection Y-Box with RJ48C connectors (16E1)		

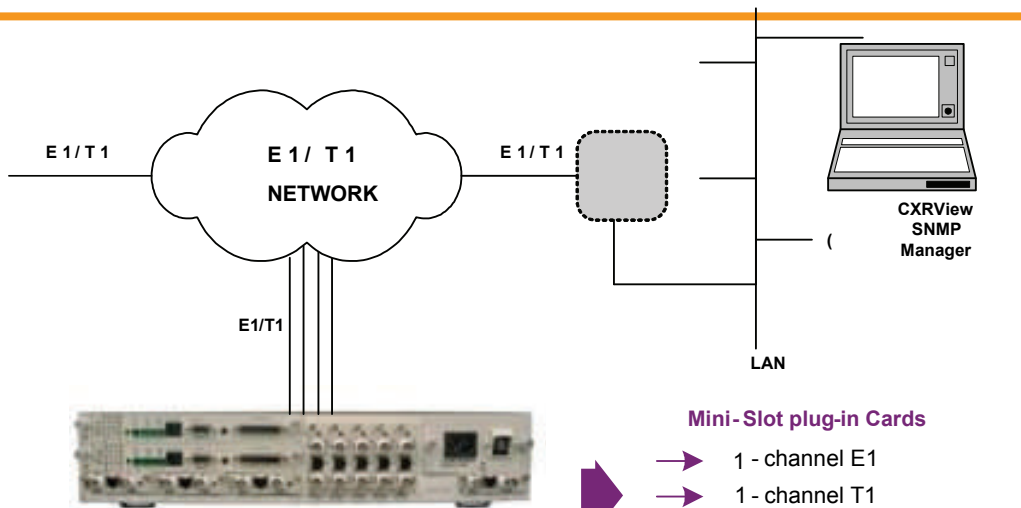

9 mini slot
Compatible with IX4200-9

Mini-Slot plug-in Cards

- ➔ 1 - channel E1
- ➔ 1 - channel T1
- ➔ Mini Quad E1
- ➔ 1 - channel E1 ATM Frame Relay
- ➔ 1 - channel T1 ATM Frame Relay
- ➔ 32 WAN port Router
- ➔ 64 WAN port Router
- ➔ Fiber Optical Interface
- ➔ 3 - channel Terminal Server
- ➔ Quad 2 W/4W E&M
- ➔ QFXS / QFXO
- ➔ 1 - channel X.21
- ➔ 1 - channel EIA530
- ➔ 1 - channel V35
- ➔ 1 - channel V24

QX 3440 QUAD E1/T1 MUX PRODUCT SPECIFICATIONS

Network Line Interface - E1, MQE1, 4E1 and 3E1 card

Line Rate	2.048 Mbps ± 50 ppm	Framing	ITU G.704
Line Code	AMI or HDDB3	Connector	BNC/RJ48C
Input Signal	ITU G.703 to -10dB	Electrical	75 ohm Coax/120 ohm twisted pair
Output Signal	ITU G.703	Jitter	ITU G.823

E1, MQE1, 4E1 & 3E1 support 1+1 protection
 4E1, MQE1 and FO 4E1 support ULSR protection
 3E1 and future FO-3E1 support SNCP protection.

Network Line Interface - T1 and 4T1

Line Rate	1.544 Mbps ± 50 bps	Output Signal	DSX1
Line Code	AMI or B8ZS	Framing	D4/ESF (selectable)
Input Signal	ABAM cable length up to 655 feet	Connector	RJ48C

Fiber Optical Interface

- ◇ 4 E1 or 4 T1 G703, G704, CAS or Non CAS
- ◇ Source LED or MLM Laser
- ◇ Wavelength Multimode 1310 & Singlemode 1310 +/- 50 nm; 1550 +/- 40 nm
- ◇ Power -26 or -8 dBm
- ◇ Receiver Sensivity -38 dBm at BER < 10 -10
- ◇ Data Rate 8 Mbps (4*2Mbps)
- ◇ Status report Card type, loopback, LOS
- ◇ Management Remote management via EOC channel
- ◇ System gain 30 dB
- ◇ Line code Scrambled NRZ
- ◇ Detector type PIN-FET
- ◇ Fiber type Single 20km and multimode 2Km
- ◇ Connector SC/PC
- ◇ Protection PDH ULSR optical ring



QX 3440 SERIAL INTERFACES - PRODUCT SPECIFICATIONS

DTE Interface (V.35)

- > Data Port 1-port DTE V.35 cards
- > Data Rate n x 64 Kbps
- > Connector DB25S (optional conversion cable DB25S to M34 connector)

DTE Interface (X21)

- > Data Port 1-port DTE X21/V11 cards
- > Data Rate 56 or 64Kbps, n = 1 to 32
- > Connector DB15F

DTE Interface (RS232)

- > Data Port 1-port RS232
- > Data Rate 1.2K, 2.4K, 4.8K, 9.6K, 19.2K, 38.4K, 48K , 64K SYNC
RS232 : 1.2K, 2.4K, 4.8K, 9.6K, 19.2K ASYNC
- > Connector DB25F
- > Clock Internal, external (TTM) , Normal or Inverted

DTE Interface (EIA530)

- > Data Port 1-port EIA530 DTE card
56 or 64Kbps, n = 1 to 32
- > Connector DB25F

DTE Interface (TS3-RS232)

- > Data Port 3-ports RS232 Async

Front panel details

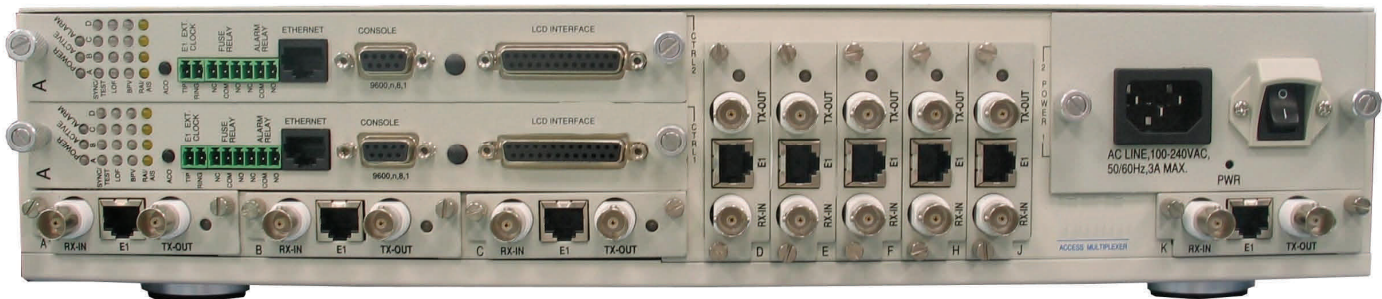

QX 3440 VOICE INTERFACES - PRODUCT SPECIFICATIONS

Voice Card (2QE&M, 4QE&M) ,

- Connector** DB44 , deliver with 4 RJ45
- Alarm Conditioning** CGA busy after 2.5 seconds of LOS, LOF
- Nb of Wires** 2 wires for 2QE&M model, 4 wires for 4QE&M model
- Encoding** A-law or μ -law, user selectable together for all
- Impedance** Balanced 600 or 900 ohms
- Longitudinal Rejection** 55 dB
- Longitudinal Max** 2.5 volts peak AC
- Loss Adjustment** 0, 3, 6, or 9 dB transmit & receive
- Gain Adjustment** 7 to -16 dB transmit & receive
- Signal/Distortion** > 46dB with 1004 Hz, 0dBm input
- Frequency Response** - 0.25 to -1 dB from 300 to 3400 Hz
- Signaling** Type 1, Type 2, Type 3, Type 4, and Type 5, A side and B side, Specified in purchase

All in-band signaling tones are carried transparently by the digitizing process.

Customer is responsible for in-band signaling compatibility between a telephone and a switch, or between a PBX and a switch.

E&M Signaling bits		E&M											
		M - Tx				E - Rx							
		A	B	C	D	A	B	C	D				
NOTE: * = Don't care.													
Normal	IDLE - ON HOOK	0	0	0	1	0	0	*	*				
	ACTIVE - OFF HOOK	1	1	0	1	1	1	*	*				
A-Bit Invert	IDLE - ON HOOK	1	1	0	1	1	1	*	*				
	ACTIVE - OFF HOOK	0	0	0	1	0	0	*	*				

Voice Card (4 FXS, 4 FXO)

- Connector** RJ11 (4 plug-in)
- Power for QFXS** 110-240VAC or -48VDC
- Power for QFXO** 110-240VAC , -48VDC or -24VDC
- Alarm Conditioning** CGA busy after 2.5 seconds of LOS, LOF
- Encoding** A-law or μ -law, user selectable together for all
- Impedance** Balanced 600 or 900 ohms (selectable together for all)
- Longitudinal Rejection** 55 dB
- Longitudinal Max** 2.5 volts peak AC
- Loss Adjustment** 7 to -16 dB / 0.5 step transmit & receive
- Signal/ Distortion** > 46dB with 1004 Hz, 0dBm input
- Frequency Response** - 0.25 to -1 dB from 300 to 3400 Hz
- FXS Loop Feed** Nominal - 48Vdc with 10mA current limit
- FXO Ringing REN** 0.1B (AC)
- FXS Ringing** 1REN at 5K meters per port
- 16.5Hz, 20Hz, 25Hz, 50Hz, user selectable for all
- 86 v rms (sine wave), 2 sec on 4 sec off, or 1 sec on 2 sec off optional for PLAR
- Signaling** Loop start, GND-start, Metering pulse 12KHz, 16KHz, Metering level 10dBm, DTMF, Dialing pulse
- Signaling Bit** Programmable

Signaling bits FXS/FXO NOTE 1: * = Don't care. NOTE 2: INVERT means the 0 & 1 of the A-Bit are inverted.		FXS								FXO							
		Tx				Rx				Tx				Rx			
		PLAR OFF/ON				PLAR OFF				PLAR ON							
		A	B	C	D	A	B	C	D	A	B	C	D	A	B	C	D
Normal	ON HOOK	0	1	0	1									0	*	*	*
	OFF HOOK	1	1	0	1									1	1	*	*
A-Bit Invert	ON HOOK	1	1	0	1									1	*	*	*
	OFF HOOK	0	1	0	1									0	1	*	*
Normal	NO RING					*	1	*	*	0	*	*	*	0	1	1	*
	RING					0	0	*	*	1	1	*	*	0	0	1	*
A-Bit Invert	NO RING					*	1	*	*	1	*	*	*	0	1	1	*
	RING					0	0	*	*	0	1	*	*	0	0	1	*
Normal Battery						*	*	*	0	*	*	*	0	*	*	*	0
Reverse Battery						*	*	*	1	*	*	*	1	*	*	*	1

All in-band signaling tones are carried transparently by the digitizing process. All in-band signaling tones are carried transparently

QX 3440 ROUTER/BRIDGE CARD - PRODUCT SPECIFICATIONS

Router/Bridge QX34DD-RTA (1/2 slot)

Number of ports	2 LAN ports, 64 WAN from 1 to 32 IT
Interface	2 * 10/100 BaseT
Connector	2 RJ45
Function	Bridge and Router
Routing Protocol	RIP-I, RIP-II, OSPF
VLAN	Transparent au VLAN or Tagging or VLAN mapping per IT
Protocols	TCP/IP, PPP, MLPPP, HDLC, HDLC Cisco, Frame Relay
Rates	N* 64K channelized over E1/T1 Maxi 2Mbps or 4Mbps en MLPPP
Function	Server et Relay DHCP, QoS
Protocol	Rapid Spanning Tree Protocoles 802.1w
Security	NAT, NAT, Firewall
Management	Over the QX3440 or IN-Band over 1 TS or over Ethernet

QX 3440 SYSTEM - PRODUCT SPECIFICATIONS

MAIN

Front Panel

LED 1 per V.35 interface, ACO, Power, SYNC/TEST, LOF, BPV, RAJ/AIS

Physical /Electrical

Dimensions **QX3440-D 2U- 19"** 438 x 88 x 224 mm (W x H x D)

Power **QX3440-S-PW48** Single or Dual -48V DC (-36 to -72V) 100 Watts max
QX3440-S-PW24 Single or Dual -24V DC (-24V) 100 Watts max
QX3440-S-PWAC Single 110/240V AC 150 Watts max

Temperature 0-55°C

Humidity 0-95%RH (non-condensing)

Mounting Desktop stackable, 19" /23" rack mountable

Line Power Supply N/A

Clock Source

- ◇ Internal, E1/T1 Line, External, SSM modes mainly used for Ring

Alarm Relay

- ◇ Alarm Relay, Fuse alarm, and performance alarm

System Configuration Parameters

- ◇ Active Configuration, Stored Configuration, and Default Configuration (Stored in Non-volatile Memory)

Supervisor

- ◇ RS232, VT100 - front panel
- ◇ 10 Base-T, Ethernet, SNMP - front panel
- ◇ In-band 64 Kbps

Performance Monitor

- ◇ **Performance Registers** Last 24 hours performance in 15 minutes interval and last 7 days in 24 hours summary
- ◇ **Separate Registers** 12 MDSL ports, network, user, and remote site
- ◇ **Performance Reports** Reports include MDSL port unsync Date & Time, Errored Second, Unavailable Second, E1 Bursty Errored Second, Severe Errored Second, Degraded Minutes, and Controlled Slip Second. Also available in Statistics (%).
- ◇ **Alarm Queue** Containing 40 alarm records which record the latest alarm type, location, and date & time
- ◇ **Threshold** Bursty Seconds, Severely Errored Second, Degraded Minutes

Diagnostics Test Line

- ◇ **Loopback** E1/T1 interface (Line Loopback, Payload Loopback, Local Loopback)
MDSL interface (Payload Loopback, Local loopback)
U interface (Local Loopback, Payload Loopback)
- ◇ **Test Pattern** E1/T1 interface (215-1 PRBS, 3-in-24, 1-in-8, 2-in-8, 1:1 patterns)
U/MDSL/DTE interface (211-1 BERT)

SIGNAL PROTECTION

MSP or 1+1 protection for Bus infrastructures for E1 or nxE1

This protection is working with unframed or framed E1 and will protect a full E1.

This mode of protection is supported by all E1 or T1 QX3440 cards (1E1, 4E1, MQE1, MQT1, 4E1, 3E1 and Fiber-optic QE1 or QT1).

This QX3440 system of protection can work face to all CXR multiplexer in 1+1 protection mode and face to several equipment from other vendor.

The Working card and Protection cards must be adjacent in the chassis.

The switching of interfaces is based on LOF, LOS , AIS or bad quality signal.

The QX3440 can support together many 1+1 protection toward different directions.

PDH ULSR Ring protection for E1 or n x E1

This protection is working with framed E1 and will protect a full E1 or several E1 in parallel and in Ring infrastructure.

This mode of protection is supported by the 4E1, MQE1 and Fiber-optic QE1 card only but only with QX3440 equipment, even E1 can be forward over any E1 PDH/SDH equipment over a clear channel transmission.

The transmission is Unidirectional, then the Working path is using the one direction of the E1 ring pipe and the Protection path will use the reverse direction or the codirectional pair of the E1 pipe when the ring will be cut.

TS can be dropped and inserted at any node of the ring to create several “point to point connection” of x TS. The E1 ULSR ring can transport maximum 31 “point to point links” over the ring.

The switching of the protection is based on LOF, LOS , AIS or the bad quality signal.

A ULSR ring with QX3440 can support several E1 rings protection, but each QX3440 of this ring can also support other rings with other QX3440 independently.

PDH SCNP protection for TS (64K) or n x TS

This protection mode is working with framed signal and will protect independently one TS (64kbps) or n TS. This SNCP protection is based on Ring infrastructure.

This protection is supported by the 3E1 and a future Fiber-optic 3E1 cards only.

This mode of protection can work with QX3440 only, but the E1 links can be forwarded over any PDH or SDH equipment in clear channel transmission.

The PDH SNCP protection can be set with Unidirectional or Bidirectional transmission.

The Working traffic and Protection traffic are always transmitted together over an E1 working path and an E1 protection path.

In case of interruption of the Working path the concerned QX3440 will generate AIS-TS in each protected TS, to order the switch on both end of the SNCP pipe.

This protection is very efficient and is avoiding the loss of data.

The QX3440 can support many TS ring protection between the same QX3440 or with other QX3440 toward different directions by using sometime the same E1 for some section of the rings.

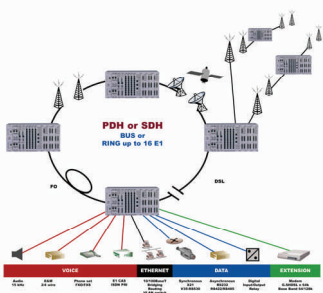

CXR ANDERSON JACOBSON

Rue de l'Ornette
28410 Abondant – France
Tél. 33 (0) 2 37 62 87 90
Fax 33 (0) 2 37 62 88 01

CXR LARUS

894 Faulstich Court
San Jose—CA95112—USA
Tél. 00 1 408 573 2733
Fax 00 1 408 573 2708